

# SPECIFICATION

**RoHS  
COMPLIANT**

ITEM P/N	CM4532A-SERIES	TEST INSTRUMENT	4291B · 4339B
PRODUCT	COMMON MODE CHOKE	TEST FREQUENCY	100 MHz / 0.5V

### PACKING DIMENSIONS (mm)

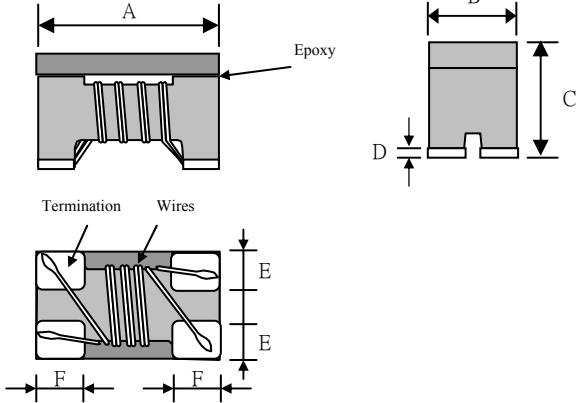

### Recommended Footprint(mm)

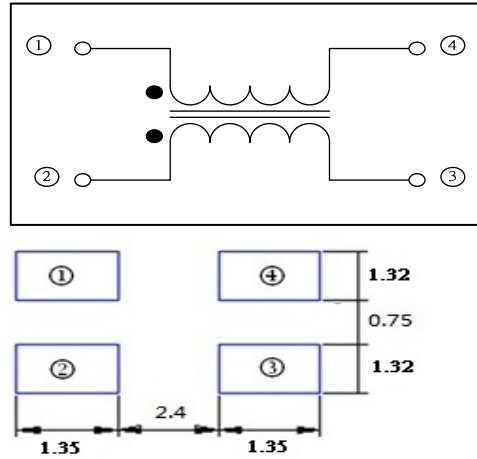

### EXPLANATION OF PART NUMBERS

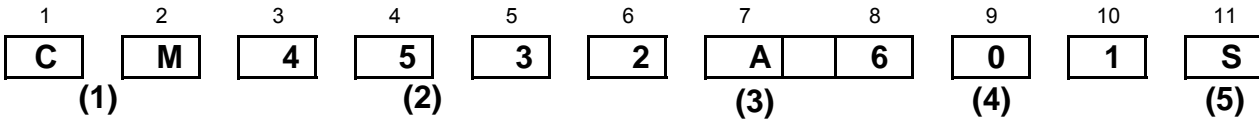

(1) Product Symbol: Chip common mode choke

(2) Shapes and dimensions: Length(A) x Width(B) x Thickness( C)  
Dimensions in mm (inch)

TYPE	A	B	C	D	E	F
0806	0.85± 0.1	0.65± 0.1	0.45 max.	0.15 max.	0.27Typ.	0.22Typ.
1210	1.2 ± 0.2	1.0 ± 0.2	0.9 max.	0.15 max.	0.36Typ.	0.33Typ.
1608	1.6 ± 0.1	0.8 ± 0.1	1.1 ± 0.1	0.1 ± 0.1	0.25Typ.	0.33Typ.
2012	2.0 ± 0.2	1.2 ± 0.2	1.2 ± 0.2	0.2 ± 0.1	0.40Typ.	0.45Typ.
2520	2.5 ± 0.2	2.0 ± 0.2	1.8 ± 0.2	0.2 ± 0.1	0.4 ± 0.1	0.45 ± 0.1
3216	3.2 ± 0.2	1.6 ± 0.2	1.9 ± 0.2	0.2 ± 0.1	0.60Typ.	0.60Typ.
3225	3.2 ± 0.2	2.5 ± 0.2	2.2 ± 0.2	0.2 ± 0.1	0.80Typ.	0.65Typ.
4532	4.5 ± 0.2	3.2 ± 0.2	2.8 ± 0.2	0.2 ± 0.1	1.2Typ.	1.0Typ.

(3)Shielding Type :

A	1GHz	USB2.0/IEEE1394 Signal Line
B	3.5GHz	HDMI 1.4 CAT1
C	6GHz	HDMI 1.4 CAT2/Display Part
D	7.5GHz	HDMI 1.4 CAT2/USB3.0
E	10GHz	HDMI 1.4 CAT2/ USB3.0

(4) Impedance 【 at 100MHz】

**601:600Ω; 801:800Ω; 102:1000Ω**

(5) Tolerance

**S=±25% ; M=±20%**

# CHARACTERISTICS

**RoHS  
COMPLIANT**

ITEM P/N	CM4532A-SERIES	TEST INSTRUMENT	4291B、4339B
PRODUCT	COMMON MODE CHOKE	TEST FREQUENCY	100 MHz / 0.5V

## ELECTRICAL CHARACTERISTICS

P/N	Z(Ω)	DCR (Ω)	Rated current	Rated Voltage	Insulation Resistance
	Common Mode				
	Impedance at 100MHz	[ Max ]	I <sub>dc</sub> (A)	V <sub>dc</sub> (V)Typical	IR (MΩ)Min.
CM4532A-601S	600	0.30	1.5	50	10
CM4532A-801S	800	0.10	1	50	10
CM4532A-102S	1000	0.40	1	50	10

Operating temperature : -25 to +85℃

Storage temp. and humidity : -40 to +85℃ ,70%RH max

Typical Heat Rating DC Current would cause an approximately ΔT of 40℃

## PERFORMANCE CURVES

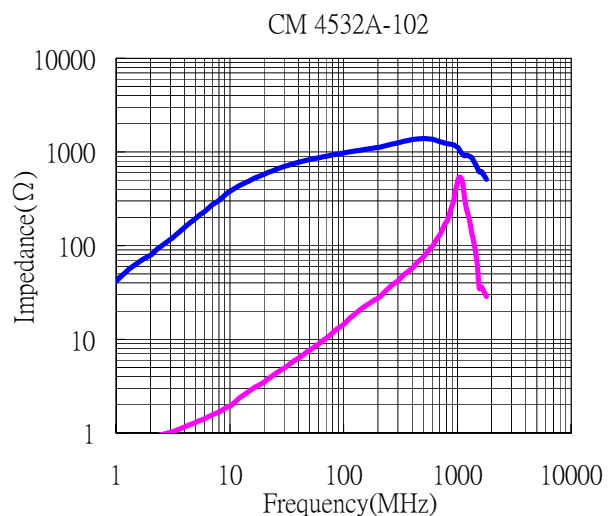
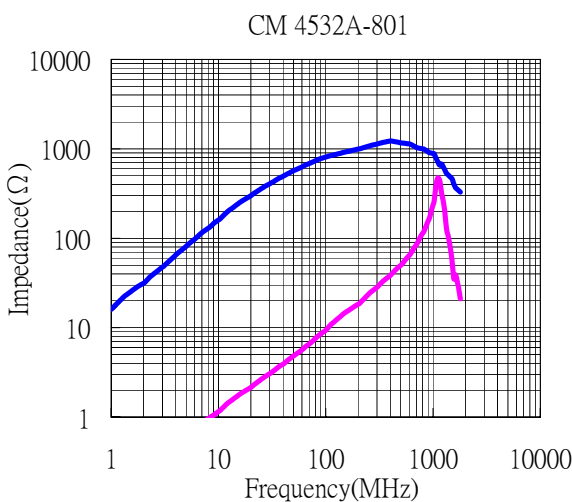
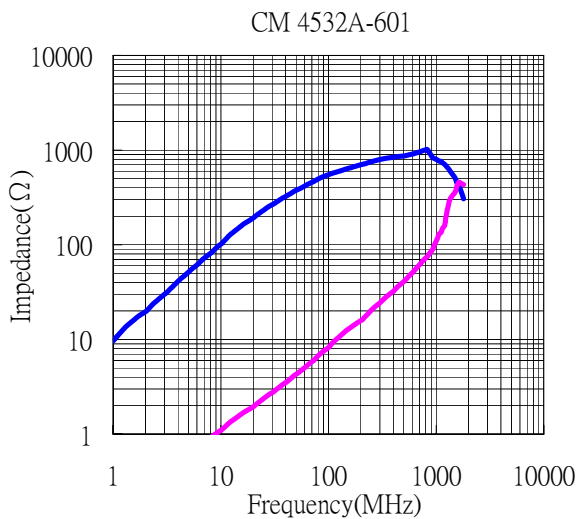

# CHARACTERISTICS

**RoHS  
COMPLIANT**

ITEM P/N	CM4532A-SERIESTEST	INSTRUMENT	4291B · 4339B
PRODUCT	COMMON MODE CHOKE	TEST FREQUENCY	100 MHz / 0.5V

## Test Equipment

### Impedance

Measured by using Agilent 4291A RF Impedance Analyzer.

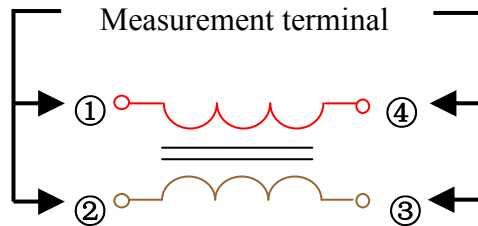

### DC Resistance

Measurement terminal

Measured by using Chroma 16502 mill ohm meter.

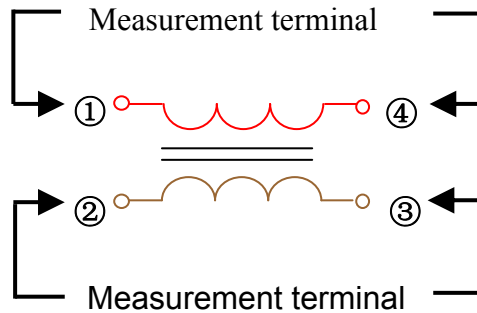

### Insulation Resistance

Measured by using Chroma 19073

Measurement voltage : 50v ,Measurement time : 60 sec.

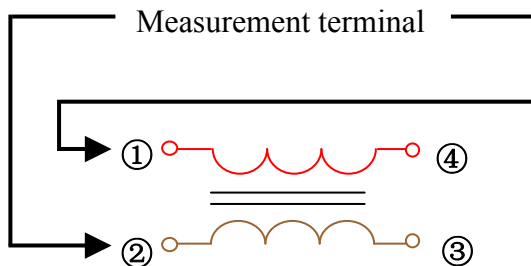

# RELIABILITY

**RoHS  
COMPLIANT**

ITEM P/N	CM4532A-SERIES	TEST INSTRUMENT	4291B · 4339B
PRODUCT	COMMON MODE CHOKE	TEST FREQUENCY	100 MHz / 0.5V

## RECOMMENDED SOLDERING TEMP. GRAPH

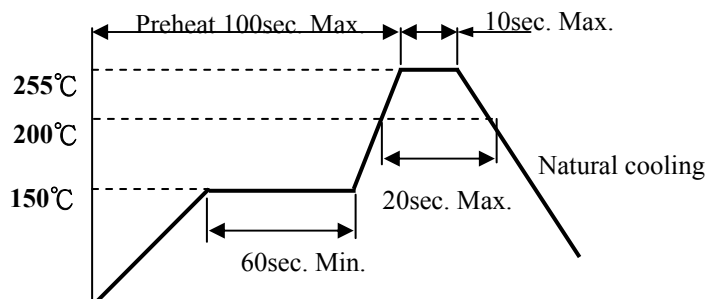

## MECHANICAL RELIABILITY

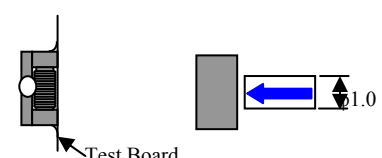
TEST	Specification & Requirement	Method Used
Solderability	The surface of terminal/pin tested shall be covered with new solder by 90%	Solder heat proof: Preheating: 150 ±10°C 60 seconds Soldering: 230 ±5°C for 3 ±1 sec
Solder Heat Resistance	Components should have not evidence of electrical and mechanical damage Impedance: within ±15% of initial value	Preheating: 150°C 60secs Solder temperature: 260±5°C Flux: rosin Dip time: 10±0.5 secs
Terminal strength	Series No.	F (Kg)
	1608	0.5
	2012	0.5
	3216	1.0
	4532	1.0
		Solder a chip to test substrate and then laterally apply a force in the arrow direction
		

## ENDURANCE RELIABILITY

TEST	Specification & Requirement	Method Used
Thermal Shock	Impedance change within ± 15% Without mechanical damage	-65°C, (30 mins) -> room temp. (2 mins) -> 125°C, (30 mins) -> room temp. (2 mins) 50 cycles
Humidity Resistance	Impedance change within ± 15% Without mechanical damage	Apply IDC current @ 60°C ambient Humidity: 90% Duration: 168 hrs
Low Temp. Storing	Impedance change within ± 15% Without mechanical damage	Storing Temp. -40 ±2 °C for total 168 +5/-0 hours
High Temp. Storing	Impedance change within ± 15% Without mechanical damage	Storing Temp. 125 ±2 °C for total 168 +5/-0 hours

# PACKING FOR SMD

**RoHS  
COMPLIANT**

ITEM P/N	CM4532A-SERIE	TEST INSTRUMENT	4291B、4339B
PRODUCT	COMMON MODE CHOKE	TEST FREQUENCY	100 MHz / 0.5V

## Reel Dimension & Tape Dimension

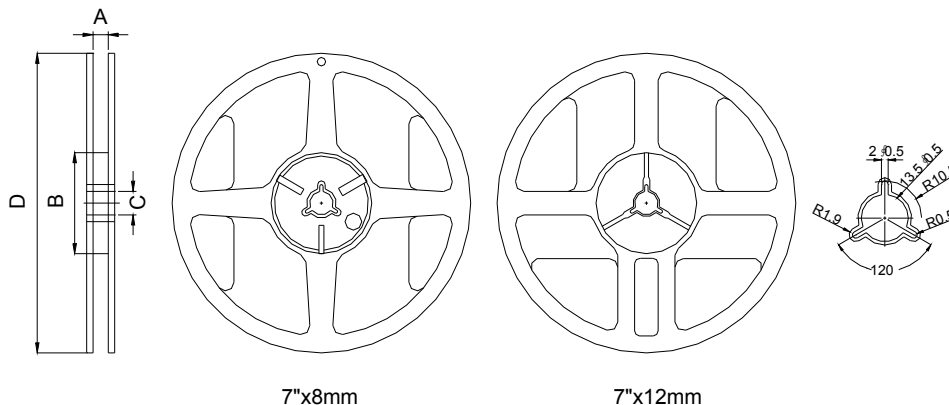

Type	A(mm)	B(mm)	C(mm)	D(mm)
7"x8mm	9.0±0.5	60±2	13.5±0.5	178±2
7"x12mm	13.5±0.5	60±2	13.5±0.5	178±2

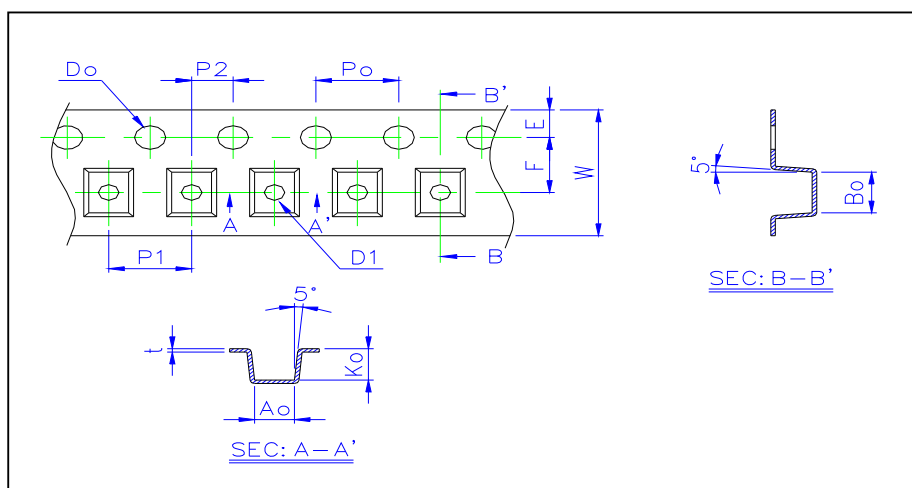

Size	Ao(mm)	Bo(mm)	Ko(mm)	W(mm)	E(mm)	F(mm)	Po(mm)	P1(mm)	Do(mm)
0806	0.95±0.10	1.05±0.10	0.50±0.10	8.00±0.20	1.75±0.10	3.50±0.05	4.0±0.05	4.0±0.10	1.5+0.1,-0
1210	1.15±0.10	1.40±0.10	0.93±0.10	8.00±0.20	1.75±0.10	3.50±0.05	4.0±0.05	4.0±0.10	1.5+0.1,-0
1608	1.65±0.10	1.00±0.10	1.18±0.10	8.00±0.20	1.75±0.10	3.50±0.05	4.0±0.05	4.0±0.10	1.5+0.1,-0
2012	2.35±0.10	1.50±0.10	1.45±0.10	8.00±0.20	1.75±0.10	3.50±0.05	4.0±0.05	4.0±0.10	1.5+0.1,-0
2520	2.75±0.10	2.20±0.15	2.00±0.10	8.00±0.20	1.75±0.10	3.50±0.05	4.0±0.05	4.0±0.10	1.0±0.1
3216	3.50±0.10	1.88±0.10	2.10±0.10	8.00±0.20	1.75±0.10	3.50±0.05	4.0±0.05	4.0±0.10	1.5+0.1,-0
3225	3.60±0.10	2.80±0.10	2.20±0.10	8.00±0.20	1.75±0.10	3.50±0.05	4.0±0.05	4.0±0.10	1.0±0.1
4532	3.45±0.10	4.90±0.10	3.05±0.10	12.00±0.20	1.75±0.10	5.50±0.05	4.0±0.05	8.0±0.10	1.5+0.1,-0

## Packaging Quantity(Unit : PCS)

Chip Size	0806	1210	1608	2012	2520	3216	3225	4532
8mm/ Reel	4000	3000	2000	2000	2000	2000	1000	500